

REFERENCE PANEL

GUIDANCE NOTES



CONCRETE FINISHES

To BS8110

and

National Structural Concrete Specification

Edition 3

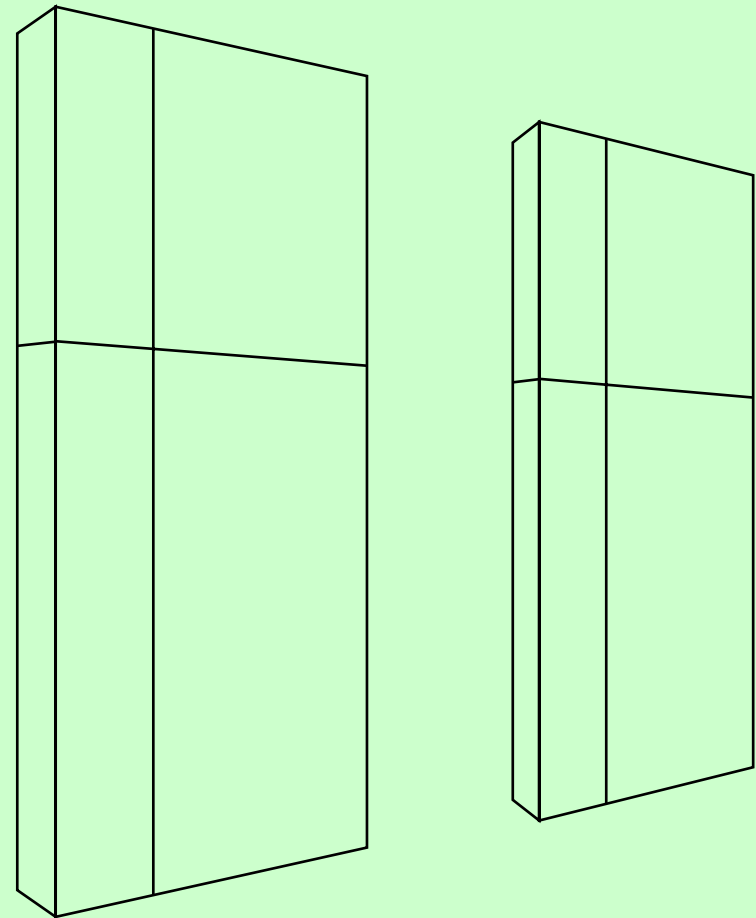

CONSTRUCT
concrete structures group

Riverside House • 4 Meadows Business Park
Station Approach • Blackwater
Camberley • Surrey GU17 9AB
Tel: 01276 38444 • Fax: 01276 38899
Website: <http://www.construct.org.uk>



CONSTRUCT Concrete Structures Group Limited is an association, membership of which is based on specialist concrete contractors and associated companies in the supply chain, notably those in the ready mixed concrete, formwork and reinforcement industries. Its objectives are to promote excellence in concrete structures and to introduce measures which will improve construction efficiency and productivity.

**For further information on CONSTRUCT
contact**

The Executive Secretary

Tel: 01276 38444 • Fax: 01276 38899

E-mail: enquiries@construct.org.uk

The members of CONSTRUCT identified the need for physical reference panels to demonstrate typical finishes. The DETR agreed and offered 50% funding for a project to produce and locate panels at strategic sites throughout the UK. The National Concrete Frame Specification (NCFS) and subsequently, the National Structural Concrete Specification for Building and Construction, adopted the standards for concrete finish given in BS8110 and the reference panels and guidance notes have been produced for use with both specifications.

CONCRETE FINISHES - REFERENCE PANELS
GUIDANCE NOTES FOR INTERPRETATION AND USE

(Refer also to National Concrete Frame Specification Clause 4.6.1 and BS8110 Section 6)

Introduction

These panels constitute a realistic, consistently achievable standard as a benchmark for the benefit of the construction industry. They represent interpretations of the most often used finishes in situ concrete, agreed by a committee of experienced, professional practitioners appointed by CONSTRUCT.

It is impossible to produce panels with a perfect finish straight from the formwork. Neither is it practical to produce panels with a ‘just acceptable’ range of blemishes such as blowholes, surface irregularities, colour variation and arris lines. The panels produced have therefore been assessed in conjunction with these guidance notes. They should be reviewed from a standard distance of 3 metres and the prevailing light and ambient conditions should be taken into consideration.

Information on the materials and methods used are only for background information. The panels are considered to be representative, irrespective of the type of material, methods and reuses of formwork used.

Index

| | | | |
|----------------------------|-----------|----------------------------|-----------|
| Introduction..... | Page 1 | Type B Finish Panels | Pages 6-7 |
| Details of Panels | Pages 2-3 | Locations..... | Pages 8-9 |
| Type A Finish Panels | Pages 4-5 | | |

These panels were provided by CONSTRUCT Concrete Structures Group Ltd in association with Department of the Environment Transport and the Regions under a Partners in Technology contract.

The site has been generously provided by the **University of Sheffield**. CONSTRUCT gratefully acknowledges their co-operation and support.

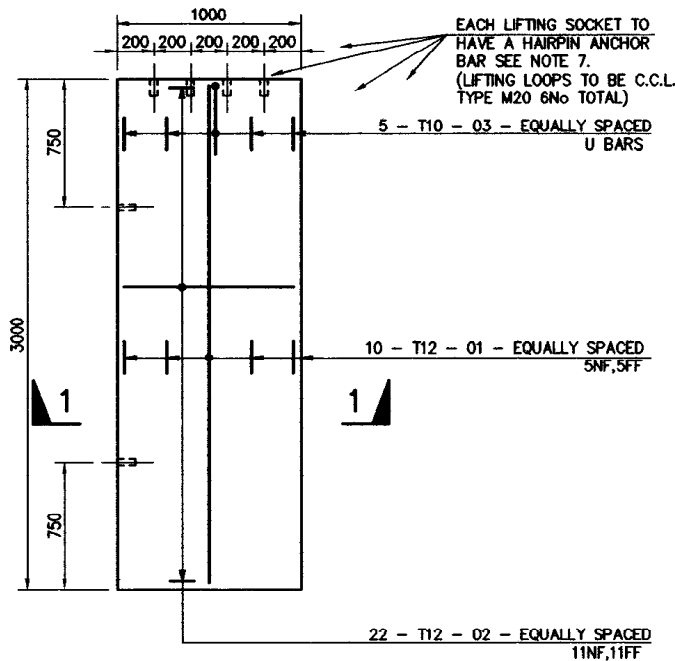

WALL ELEVATION

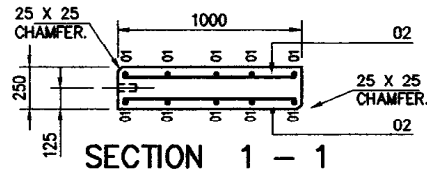

SECTION 1 - 1

DIMS. TO B.S.4466

| MARK | TYPE & SIZE | TOTAL No. | LENGTH | SHAPE CODE | A | B |
|------|-------------|-----------|--------|------------|----------|-----|
| 01 | T12 | 10 | 2900 | 20 | STRAIGHT | |
| 02 | T12 | 22 | 900 | 20 | STRAIGHT | |
| 03 | T10 | 5 | 900 | 38 | 400 | 180 |

T - TYPE 2 DEFORMED BARS, GRADE 460 COMPLYING WITH BS 4449.

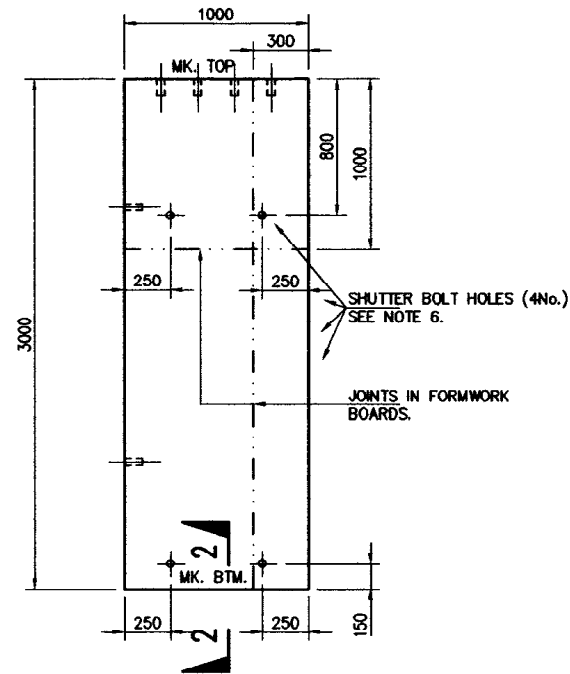

FORMWORK ELEVATION

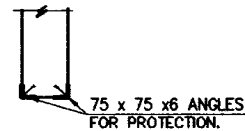

SECTION 2 - 2

NOTES

1. CONCRETE TO BE GRADE C 35 TO BS5328.
 2. REINFORCEMENT TO BE HIGH YIELD.
 3. COVER TO ALL BARS TO BE 40mm.
 4. MANUFACTURER TO PROVIDE SPACERS BETWEEN REINFORCEMENT MATS AS REQD. AND MAY TAKE THE FORM OF REINFORCEMENT U BARS. ALL TIE WIRE ENDS MUST BE TURNED IN, AWAY FROM THE PANEL FORMWORK SURFACE.
 5. BOLT HOLES FOR FORMWORK TO BE PLASTIC WITH CONES.
 6. ONE BOLT HOLE TO BE FILLED FLUSH (ON BOTH SIDES), AND ONE BOLT HOLE TO BE FILLED AND NEATLY RECESSED TO WITHIN 10mm BELOW SURFACE (ON BOTH SIDES).
 7. LIFTING SOCKETS TO BE C.C.L.M20 SOCKETS COMPLETE WITH 400mm LONG HAIRPIN T12 DIA. BARS ALL IN ACCORDANCE WITH MANUFACTURERS SPECIFICATIONS OR SIMILAR AGREED.
 8. TOTAL PANEL WEIGHT APPROX. 1.80 TONNES.
 9. TWO PANELS TO BE CONSTRUCTED AS FOLLOWS :
- | PANEL FINISH | EACH SIDE | FORMWORK |
|--------------|-----------|--|
| 'A' | NEW | DOUGLAS FIR CIS (GOOD ONE SIDE) WITH WOULD RELEASE AGENT. |
| | USED | |
| 'B' | NEW | PAPER FACED PLY (EVANS POURFORM) WITH WOULD RELEASE AGENT. |
| | USED | |
10. PANELS MUST BE CONSTRUCTED IN THE VERTICAL POSITION AS WALL PANELS WITH TOP & BTM. POSITIONS AS MARKED.
 11. FORMWORK TO BE OF THE SAME CONSTRUCTION TO ALL PANELS.

| | | | | |
|------|-------------------------|--------|---------|------|
| E | NOTES 1, 2, & 6 AMENDED | V.R.D. | 16/2/98 | A.W. |
| Mark | Revision | Chkd | Date | Dra |

| | |
|---|---|
| SAMPLE WALL PANELS B.S. 8110 (PART 1) TYPE 'A' & TYPE 'B' FINISH | PETER BRETT ASSOCIATES CONSULTING ENGINEERS |
|---|---|

pba
10 WESTOOTE ROAD READING BERKSHIRE RG6 3DZ TEL 01734 506791 FAX 01734 507408

| | | | |
|------------|---------|-----------|------------------|
| Scale | 1:25 | Cad Ref | C:\ALAN\TYP_MJLL |
| Date | SEPT 95 | Drawn | A.W. |
| Checked | VRD | Passed | VRD |
| Drawing No | | OPR/100 E | |

DETAIL OF PANELS - CONSTRUCTION DETAILS (North East)

| | | | | |
|--------------|---------------------|-------------------|--|--|
| CONCRETE C35 | Materials: | Cement | <i>PC</i> | - Castle, Ketton |
| | | Aggregate | <i>20-5 L/ST</i> | - Longcliffe, Brassington |
| | | Sand | <i>Sand M</i> | - RMC Aggregates, Attenborough |
| | Mix details: | | <i>Cement content</i> | - 330Kg/m ³ ; w/c 0.50; agg/cem 5.61; 37.16% sand |
| FORMWORK | Design: | Pour rate | <i>Both finishes</i> | 6 m/h |
| | | Slump | <i>Both finishes</i> | 50 mm |
| | | Temperature | <i>Both finishes</i> | Concrete +5 °C min.: Air 15-25 °C |
| | Materials: | Face sheeting | <i>Type A finish</i> <i>Type B finish</i> | Douglas fir G1S plywood; Plastic splay arris formers Resin impregnated paper faced plywood (Pourform) |
| | | Secondary support | <i>Both finishes</i> | Timber 4" x 3" nominal PAR; ply joints backed |
| | | Primary support | <i>Both finishes</i> | Steel soldiers - RMD II |
| | | Release agent | <i>Type A finish</i> <i>Type B finish</i> | Chemical - Admast Adolease Chemical - Admast Adolease |
| | REINFORCEMENT | | <i>See Page 2</i> | <i>Both panels</i> |
| CONSTRUCTION | Delivery | Concrete | <i>Both finishes</i> | Ready mixed (approx 30 min travel) |
| | Slump | Concrete | <i>Both finishes</i> | 50 mm |
| | Placing | Concrete | <i>Both finishes</i> | Crane and skip |
| | Pour rate | Concrete | <i>Both finishes</i> | 5 m/hr |
| | Compaction | Concrete | <i>Both finishes</i> | Internal vibrator - 50mm poker petrol driven |
| | Temperature | | <i>Both finishes</i> | Concrete (unknown) ; Air 8 °C |
| | Striking | Formwork | <i>Both finishes</i> | After approx. 24 hours |
| | Curing | Concrete | <i>Both Finishes</i> | Exposed to the weather for 7 days |

TYPE A FINISH - GUIDANCE

Type A finish is normally used where appearance is not critical, the concrete is not exposed to view or where a regular surface is required for applied finishes such as plaster or render. Preparation would be required to fill blemishes and reduce irregularities if the surface is to be painted.

The following variations in the finish are permitted:

| | |
|-----------------------|--|
| General | The formwork face material may leave a wood grain imprint on the concrete, but this is not specifically part of the finish. The constructor is free to use a different type of face material, to give greater re-use of the form face, but the surface must be suitable for the application of the required finish. |
| Colour | There are no requirements for colour consistency or shade with this finish. |
| Blowholes | Permitted up to 20mm dia (ie covered by a 1p coin) measured on the surface Permitted up to 10mm deep measured from the surface Frequency of blemishes to be spread over the pour as described in the interpretation on page 5. |
| Abrupt Irregularities | Permitted up to 3mm, but up to 5mm at construction or movement joints, as measured on the normal surface of the finished face. Frequency of irregularity to be spread over the pour and as illustrated in the interpretation on page 5 This irregularity is independent of any tolerance allowed in the construction and is meant to encompass formwork face irregularities. |
| Making Good | Making good is permitted to improve the finish. |

This finish can be suitable for use as a Class 2 finish as outlined in BS8110 6.2.7.2 at the specifier's discretion. Type A finish is not applicable to Class 1 and Special Class finishes.

TYPE A FINISH - INTERPRETATION (North East)

SIDE 1 first use

SIDE 2 reused

These panels are typical of what should be expected of a Type A finish subject to the comments below

Surface Blemishes

Blowholes larger than specified may need filling for exposed finish
Note: Mastic sealing of joints in formwork would reduce grout loss at edges

Abrupt Irregularities

Poker damage to form face need removed for exposed finish
All joints and 'nailheads' within specification

Making Good

Grout loss should be made good (as done to panel return)
Typical bolt hole making good shown - recessed and flush

General

Both side have a greater frequency of small and large blowholes than should be expected

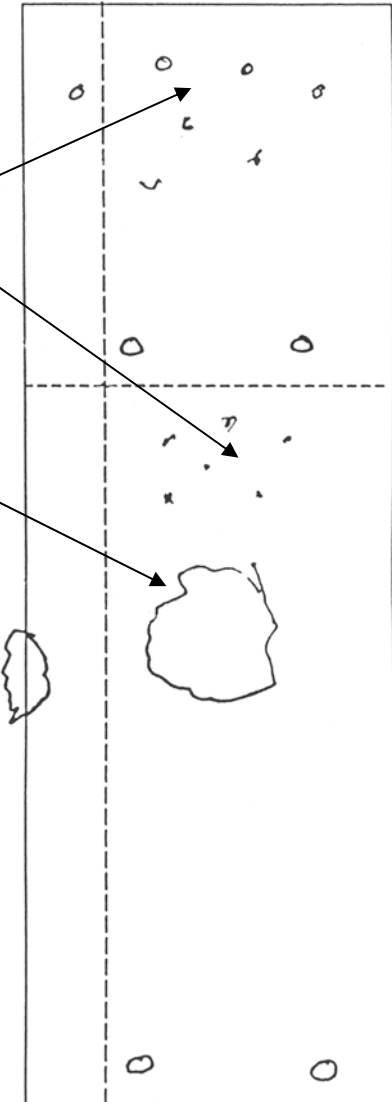
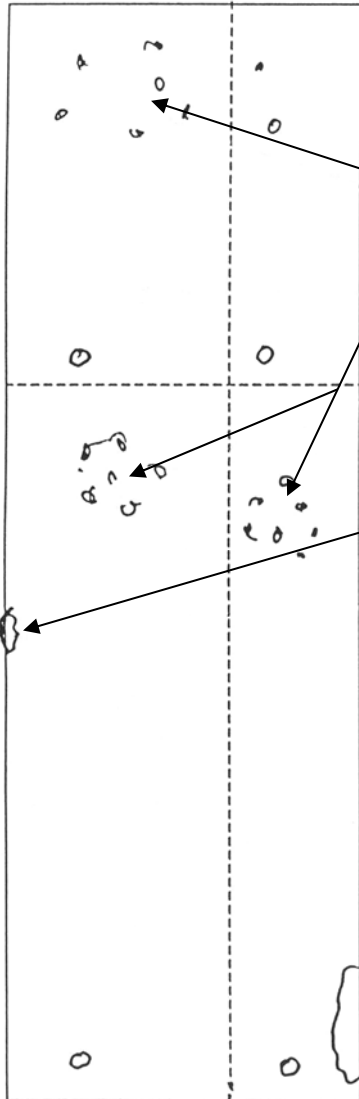

TYPE B FINISH - GUIDANCE

Type B finish is normally used where the finish is exposed to view in the completed works. The suitability of the finish should have regard to BS8110 6.2.7.1 and 6.2.7.3 which states it is “impossible to achieve dense, flat, smooth, even-coloured, blemish-free concrete surfaces direct from the formwork”. Type B finish is as-struck from the forms and any subsequent working of the face will result in type C finish.

The following variations to the finish are permitted:

| | |
|-----------------------|--|
| General | The formwork face material will leave marks from the sheet edges and perhaps some local dark discolouration. The constructor is free to use a different type of face material, to give greater re-use, but the surface must meet the requirement of type B finish. |
| Colour | Variation in colour should be kept to a minimum, but attention is drawn to the guide on appearance above and in the interpretation on page 7. |
| Blowholes | Permitted up to 10mm dia (approx diameter of a pen) measured on the surface Permitted up to 5mm deep measured from the surface Frequency of void to be spread over the pour and as described in the interpretation on page 7. |
| Abrupt Irregularities | Permitted up to 2mm, but up to 3mm at construction or movement joints, as measured on the normal surface of the finished face Frequency of irregularity to be spread over the pour and as illustrated in the interpretation on page 7 This irregularity is independent of any tolerance allowed in the construction and is meant to encompass formwork face irregularities |
| Making Good | Making good should not be used to improve the finish. If the finish is to be improved it should be categorized as a Type C finish. Making good as a remedial action may be permitted, but care in colour matching is required. |

This finish can be suitable for use as a Class 1 or Class 2 finish as outlined in BS8110 6.2.7.2 at the specifier’s discretion. Type B finish is not applicable to Special Class finishes.

TYPE B FINISH - INTERPRETATION (North East)

SIDE 1 first use

SIDE 2 reused

These panels are typical of what should be expected of a Type B finish subject to the comments below

Surface Blemishes

Larger holes require filling to meet 10mm requirement and fewer should be expected

Note examples of bolt hole filling - flush and recessed

Note: Mastic sealing of joints in formwork would reduce grout loss at edges

Abrupt Irregularities

All within 2mm requirement

Colour

Black stains caused by handling during erection of panels
Color variation is as expected on reuse may reduce with weathering

General

Both sides meet the specification with filling of large hole blemishes

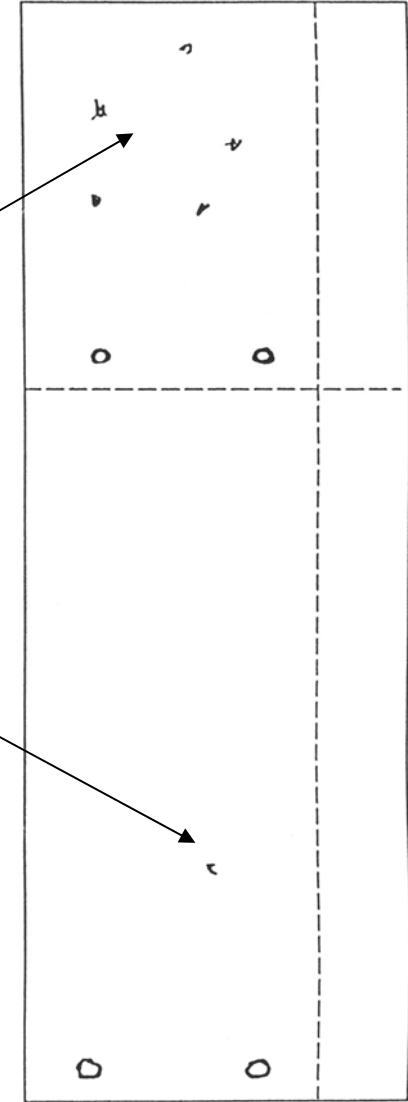
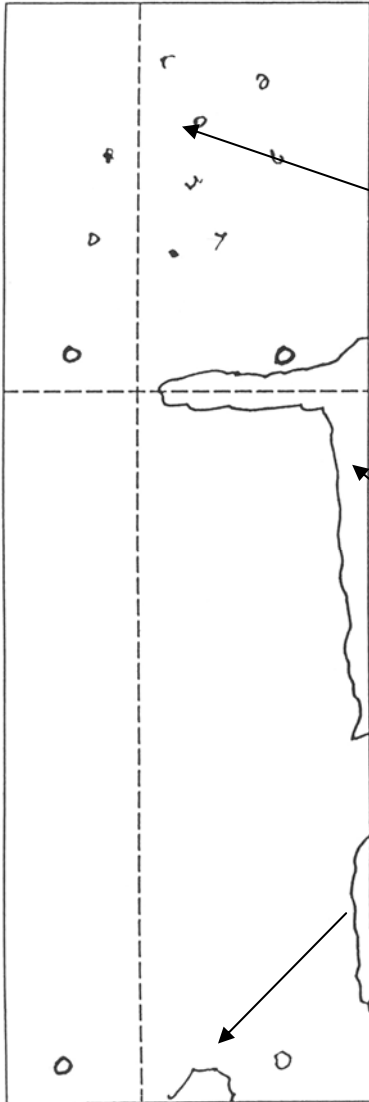

LOCATION OF ALL SITES IN UK DISPLAYING PANELS

| | | | |
|---------------------------------------|---|---|------------------|
| London North (External Site) | John Doyle Construction Limited John Doyle House Little Burrow, Welwyn Garden City Herts AL7 2SP | Tel: 01707 329481 E-mail: graham.hardwick@john-doyle.co.uk | Graham Hardwick |
| London South (External Site) | The Medway School of Engineering Medway University Campus University of Greenwich Chatham Maritime, Kent ME4 4TB | Tel: 0208 331 8368 E-mail: t.d.stevens@gre.ac.uk | Tony Stevens |
| South West England (External Site) | University of the West of England Faculty of Environment and Technology School of Built and Natural Environment Coldharbour Lane Frenchay Bristol BS16 1QY | Tel: 0117 328 3191 E-mail: ghassan.nounu@uwe.ac.uk | Dr Ghassan Nounu |
| Central England (External Site) | Peri Ltd Market Harborough Road Clifton upon Dunsmore Rugby CV23 0AN | Tel: 01788 861600 E-mail: matthew.binder@peri.ltd.uk | Matthew Binder |
| North East England (Internal Site) | University of Sheffield Sir Frederick Mappin Building Mappin Street Sheffield S1 3JD | Tel: 0114 222 6690 E-mail: p.blackbourn@sheffield.ac.uk | Paul Blackbourn |
| Scotland (Internal Site) | University of Paisley High Street Paisley PA1 2BE | Tel: 0141 848 3280 E-mail: bill.matthews@uws.ac.uk | Bill Matthews |



LOCATION OF PANELS

Scotland

University of Paisley
Paisley Campus
Glasgow

North East England

University of Sheffield
Mapping Street
Sheffield

Central England

Peri Ltd
Clifton upon Dunsmore
Nr Rugby

London North

John Doyle Construction Ltd
Welwyn Garden City
Herts

London South

Medway University Campus
University of Greenwich
Chatham Maritime

South West England

University of the West of England
Coldharbour Lane
Bristol

REFERENCE PANEL

GUIDANCE NOTES



CONCRETE FINISHES

To BS EN 13670:2009

and

National Structural Concrete Specification

Edition 4

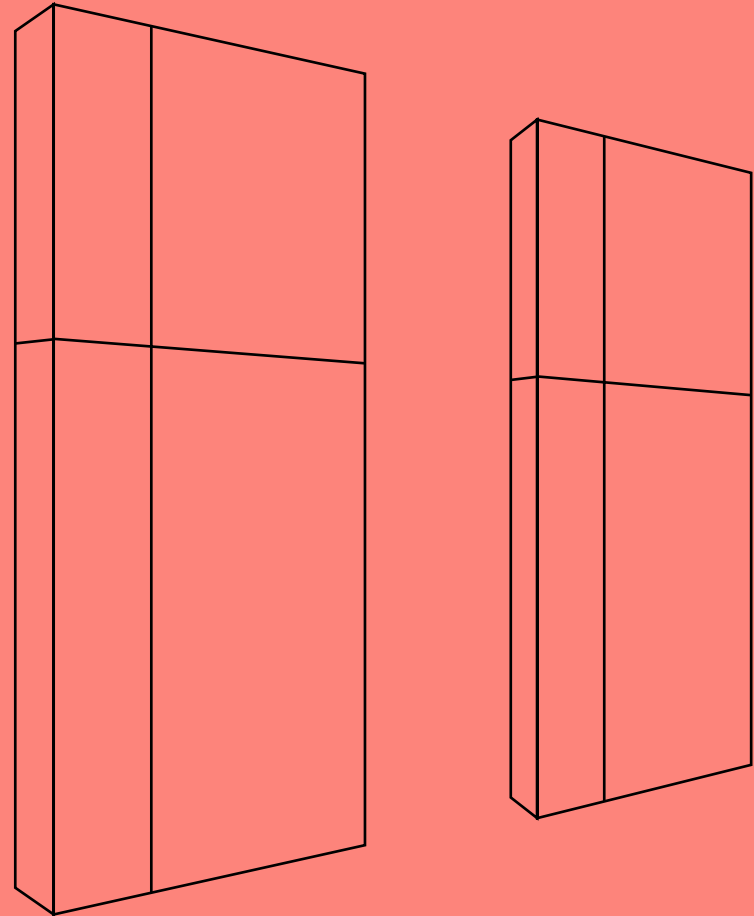

CONSTRUCT
concrete structures group

Riverside House • 4 Meadows Business Park
Station Approach • Blackwater
Camberley • Surrey GU17 9AB
Tel: 01276 38444 • Fax: 01276 38899
Website: <http://www.construct.org.uk>



CONSTRUCT Concrete Structures Group Limited is an association, membership of which is based on specialist concrete contractors and associated companies in the supply chain, notably those in the ready mixed concrete, formwork and reinforcement industries. Its objectives are to promote excellence in concrete structures and to introduce measures which will improve construction efficiency and productivity.

**For further information on CONSTRUCT
contact**

The Executive Secretary

Tel: 01276 38444 • Fax: 01276 38899

E-mail: enquiries@construct.org.uk

The members of CONSTRUCT identified the need for physical reference panels to demonstrate typical finishes. The DETR agreed and offered 50% funding for a project to produce and locate panels at strategic sites throughout the UK. The National Concrete Frame Specification (NCFS) and subsequently, the National Structural Concrete Specification for Building and Construction, adopted the standards for concrete finish given in BS8110 and the reference panels and guidance notes have been produced for use with both specifications.

The publication of BS EN 13670: 2009, Edition 4 of NSCS and withdrawal of BS 8110 changed the nomenclature of finishes but not the finish requirements. The reference panels therefore remain appropriate for the designated finishes. This guidance has been revised in accordance with the requirements of BS EN 13670 and companion specification NSCS Edition 4.

CONCRETE FINISHES - REFERENCE PANELS
GUIDANCE NOTES FOR INTERPRETATION AND USE

(Refer also to NSCS Standard Specification clause 8.6.1 and BS EN 1670: 2009 clause 8.8)

Introduction

These panels constitute a realistic, consistently achievable standard as a benchmark for the benefit of the construction industry. They represent interpretations of the most often used finishes in situ concrete, agreed by a committee of experienced, professional practitioners appointed by CONSTRUCT.

It is impossible to produce panels with a perfect finish straight from the formwork. Neither is it practical to produce panels with a ‘just acceptable’ range of blemishes such as blowholes, surface irregularities, colour variation and arris lines. The panels produced have therefore been assessed in conjunction with these guidance notes. They should be reviewed from a standard distance of 3 metres and the prevailing light and ambient conditions should be taken into consideration.

Information on the materials and methods used are only for background information. The panels are considered to be representative, irrespective of the type of material, methods and reuses of formwork used.

Index

| | | | |
|-----------------------------|-----------|---------------------------|-----------|
| Introduction..... | Page 1 | Plain Finish Panels | Pages 6-7 |
| Details of Panels | Pages 2-3 | Locations..... | Pages 8-9 |
| Ordinary Finish Panels..... | Pages 4-5 | | |

These panels were provided by CONSTRUCT Concrete Structures Group Ltd in association with Department of the Environment Transport and the Regions under a Partners in Technology contract.

The site has been generously provided by the **University of Sheffield**. CONSTRUCT gratefully acknowledges their co-operation and support.

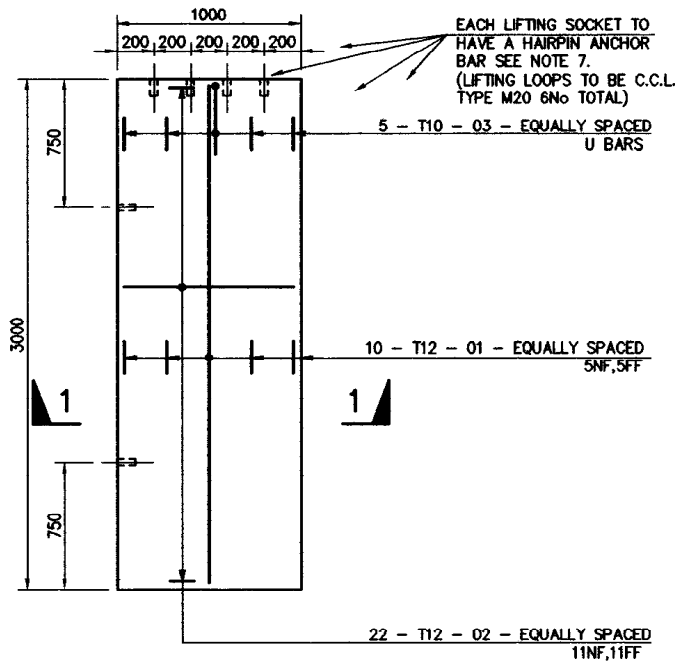

WALL ELEVATION

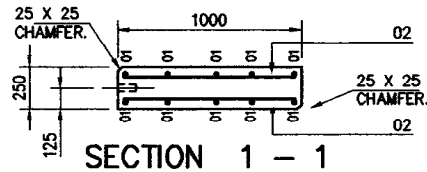

SECTION 1 - 1

DIMS. TO B.S.4466

| MARK | TYPE & SIZE | TOTAL No. | LENGTH | SHAPE CODE | A | B |
|------|-------------|-----------|--------|------------|----------|-----|
| 01 | T12 | 10 | 2900 | 20 | STRAIGHT | |
| 02 | T12 | 22 | 900 | 20 | STRAIGHT | |
| 03 | T10 | 5 | 900 | 38 | 400 | 180 |

T - TYPE 2 DEFORMED BARS, GRADE 460 COMPLYING WITH BS 4449.

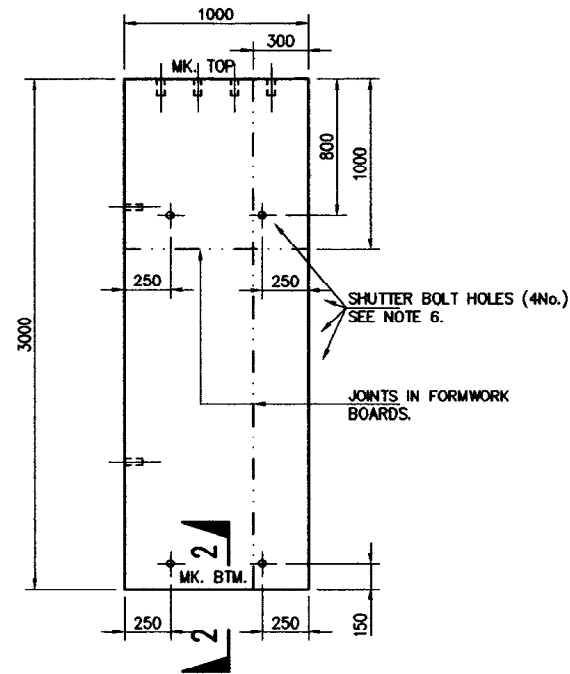

FORMWORK ELEVATION

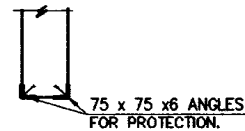

SECTION 2 - 2

NOTES

1. CONCRETE TO BE GRADE C 35 TO BS5328.
 2. REINFORCEMENT TO BE HIGH YIELD.
 3. COVER TO ALL BARS TO BE 40mm.
 4. MANUFACTURER TO PROVIDE SPACERS BETWEEN REINFORCEMENT MATS AS REQD. AND MAY TAKE THE FORM OF REINFORCEMENT U BARS. ALL TIE WIRE ENDS MUST BE TURNED IN, AWAY FROM THE PANEL FORMWORK SURFACE.
 5. BOLT HOLES FOR FORMWORK TO BE PLASTIC WITH CONES.
 6. ONE BOLT HOLE TO BE FILLED FLUSH (ON BOTH SIDES), AND ONE BOLT HOLE TO BE FILLED AND NEATLY RECESSED TO WITHIN 10mm BELOW SURFACE (ON BOTH SIDES).
 7. LIFTING SOCKETS TO BE C.C.L.M20 SOCKETS COMPLETE WITH 400mm LONG HAIRPIN T12 DIA. BARS ALL IN ACCORDANCE WITH MANUFACTURERS SPECIFICATIONS OR SIMILAR AGREED.
 8. TOTAL PANEL WEIGHT APPROX. 1.80 TONNES.
 9. TWO PANELS TO BE CONSTRUCTED AS FOLLOWS :
- | PANEL FINISH | EACH SIDE | FORMWORK |
|--------------|-----------|--|
| 'A' | NEW | DOUGLAS FIR CIS (GOOD ONE SIDE) WITH WOULD RELEASE AGENT. |
| | USED | |
| 'B' | NEW | PAPER FACED PLY (EVANS POURFORM) WITH WOULD RELEASE AGENT. |
| | USED | |
10. PANELS MUST BE CONSTRUCTED IN THE VERTICAL POSITION AS WALL PANELS WITH TOP & BTM. POSITIONS AS MARKED.
 11. FORMWORK TO BE OF THE SAME CONSTRUCTION TO ALL PANELS.

| | | | | |
|------|-------------------------|--------|---------|------|
| E | NOTES 1, 2, & 6 AMENDED | V.R.D. | 16/2/98 | A.W. |
| Mark | Revision | Chkd | Date | Dra |

| | |
|---|---|
| SAMPLE WALL PANELS B.S. 8110 (PART 1) TYPE 'A' & TYPE 'B' FINISH | PETER BRETT ASSOCIATES CONSULTING ENGINEERS |
|---|---|

pba
10 WESTOOTE ROAD READING BERKSHIRE RG6 3JZ TEL 01734 506791 FAX 01734 507408

| | | | |
|------------|---------|-----------|------------------|
| Scale | 1:25 | Cad Ref | C:\ALAN\TYP_MJLL |
| Date | SEPT 95 | Drawn | A.W. |
| Checked | VRD | Passed | VRD |
| Drawing No | | OPR/100 E | |

DETAIL OF PANELS - CONSTRUCTION DETAILS (North East)

| | | | | |
|---------------|---------------------|-------------------|---|--|
| CONCRETE C35 | Materials: | Cement | <i>PC</i> | - Castle, Ketton |
| | | Aggregate | <i>20-5 L/ST</i> | - Longcliffe, Brassington |
| | | Sand | <i>Sand M</i> | - RMC Aggregates, Attenborough |
| | Mix details: | | <i>Cement content</i> | - 330Kg/m ³ ; w/c 0.50; agg/cem 5.61; 37.16% sand |
| FORMWORK | Design: | Pour rate | <i>Both finishes</i> | 6 m/h |
| | | Consistence | <i>Both finishes</i> | 50 mm Slump |
| | | Temperature | <i>Both finishes</i> | Concrete +5 °C min.: Air 15-25 °C |
| | Materials: | Face sheeting | <i>Ordinary finish</i> <i>Plain finish</i> | Douglas fir G1S plywood; Plastic splay arris formers Resin impregnated paper faced plywood (Pourform) |
| | | Secondary support | <i>Both finishes</i> | Timber 4" x 3" nominal PAR; ply joints backed |
| | | Primary support | <i>Both finishes</i> | Steel soldiers - RMD II |
| | | Release agent | <i>Ordinary finish</i> <i>Plain finish</i> | Chemical - Admast Adolease Chemical - Admast Adolease |
| | | | | |
| REINFORCEMENT | | <i>See Page 2</i> | <i>Both panels</i> | |
| CONSTRUCTION | Delivery | Concrete | <i>Both finishes</i> | Ready mixed (approx 30 min travel) |
| | Consistence | Concrete | <i>Both finishes</i> | 50 mm Slump |
| | Placing | Concrete | <i>Both finishes</i> | Crane and skip |
| | Pour rate | Concrete | <i>Both finishes</i> | 5 m/hr |
| | Compaction | Concrete | <i>Both finishes</i> | Internal vibrator - 50mm poker petrol driven |
| | Temperature | | <i>Both finishes</i> | Concrete (unknown) ; Air 8 °C |
| | Striking | Formwork | <i>Both finishes</i> | After approx. 24 hours |
| | Curing | Concrete | <i>Both Finishes</i> | Exposed to the weather for 7 days |

ORDINARY FINISH - GUIDANCE

Ordinary finish is normally used where appearance is not critical, the concrete is not exposed to view or where a regular surface is required for applied finishes such as plaster or render. Preparation would be required to fill blemishes and reduce irregularities if the surface is to be painted.

The following variations in the finish are permitted:

| | |
|-----------------------|--|
| General | The formwork face material may leave a wood grain imprint on the concrete, but this is not specifically part of the finish. The constructor is free to use a different type of face material, to give greater re-use of the form face, but the surface must be suitable for the application of the required finish. |
| Colour | There are no requirements for colour consistency or shade with this finish. |
| Blowholes | Permitted up to 20mm dia (ie covered by a 1p coin) measured on the surface Permitted up to 10mm deep measured from the surface Frequency of blemishes to be spread over the pour as described in the interpretation on page 5. |
| Abrupt Irregularities | Permitted up to 3mm, but up to 5mm at construction or movement joints, as measured on the normal surface of the finished face. Frequency of irregularity to be spread over the pour and as illustrated in the interpretation on page 5 This irregularity is independent of any tolerance allowed in the construction and is meant to encompass formwork face irregularities. |
| Making Good | Making good is permitted to improve the finish. |

Further general guidance on the use of Ordinary finish is available in NSCS Guidance clause 8.6.1.3 which expands the brief informative description in BS EN 13670: 2009 Annex F, Table F4.

ORDINARY FINISH - INTERPRETATION (North East)

SIDE 1 first use

SIDE 2 reused

These panels are typical of what should be expected of an Ordinary finish subject to the comments below

Surface Blemishes

Blowholes larger than specified may need filling for exposed finish
Note: Mastic sealing of joints in formwork would reduce grout loss at edges

Abrupt Irregularities

Poker damage to form face need removed for exposed finish
All joints and 'nailheads' within specification

Making Good

Grout loss should be made good (as done to panel return)
Typical bolt hole making good shown - recessed and flush

General

Both side have a greater frequency of small and large blowholes than should be expected

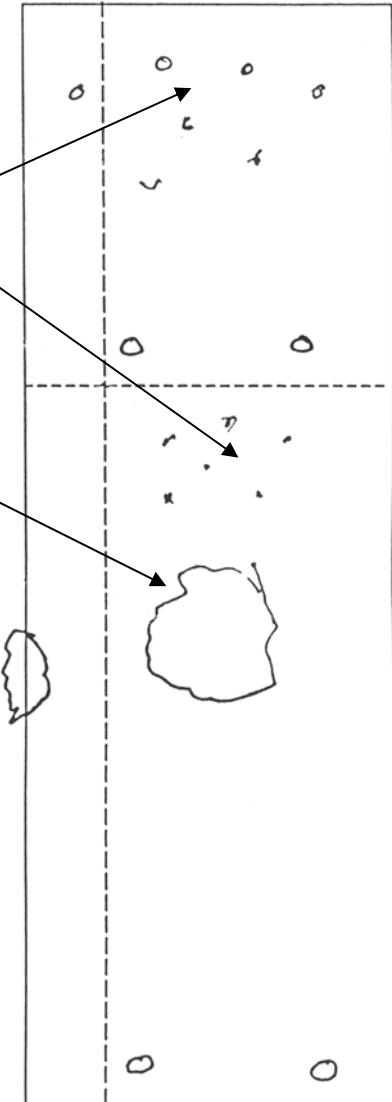
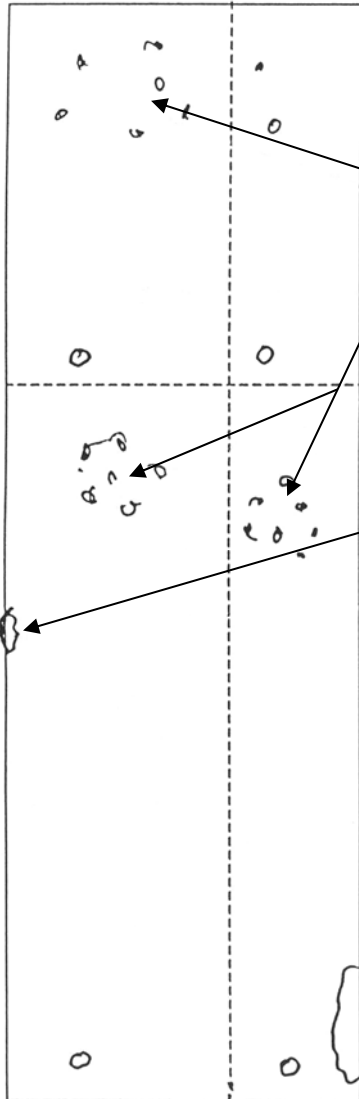

PLAIN FINISH - GUIDANCE

Plain finish is normally used where the finish is exposed to view in the completed works. The suitability of the finish should have regard to the impossibility to achieve dense, flat, smooth, even-coloured, blemish-free concrete surfaces direct from the formwork. Plain finish is as-struck from the forms and any subsequent working of the face will result in Special finish.

The following variations to the finish are permitted:

| | |
|-----------------------|--|
| General | The formwork face material will leave marks from the sheet edges and perhaps some local dark discolouration. The constructor is free to use a different type of face material, to give greater re-use, but the surface must meet the requirement of Plain finish. |
| Colour | Variation in colour should be kept to a minimum, but attention is drawn to the guide on appearance above and in the interpretation on page 7. |
| Blowholes | Permitted up to 10mm dia (approx diameter of a pen) measured on the surface Permitted up to 5mm deep measured from the surface Frequency of void to be spread over the pour and as described in the interpretation on page 7. |
| Abrupt Irregularities | Permitted up to 2mm, but up to 3mm at construction or movement joints, as measured on the normal surface of the finished face Frequency of irregularity to be spread over the pour and as illustrated in the interpretation on page 7 This irregularity is independent of any tolerance allowed in the construction and is meant to encompass formwork face irregularities |
| Making Good | Making good should not be used to improve the finish. If the finish is to be improved it should be categorized as a Special finish. Making good as a remedial action may be permitted, but care in colour matching is required. |

Further general guidance on the use of Plain finish is available in NSCS Guidance clause 8.6.1.3 which expands the brief informative description in BS EN 13670: 2009 Annex F, Table F4. NSCS Guidance clause 8.6.1.4 gives guidance on further considerations for the successful production of Special finishes.

PLAIN FINISH - INTERPRETATION (North East)

SIDE 1 first use

SIDE 2 reused

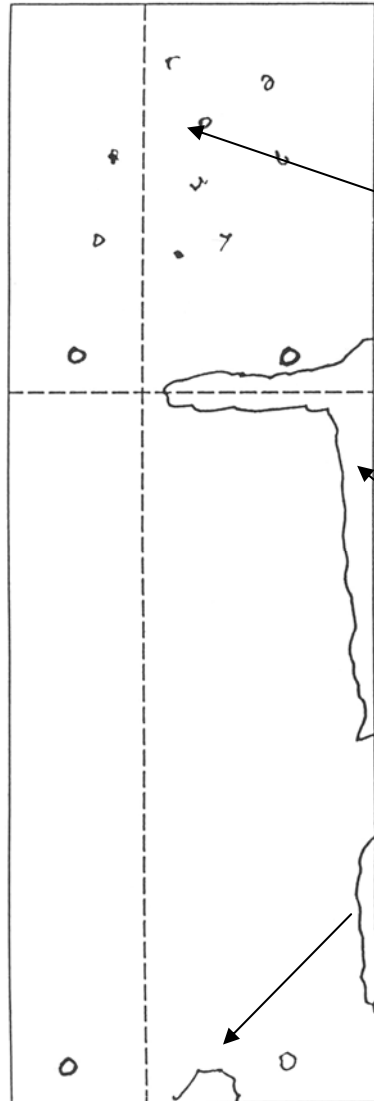

These panels are typical of what should be expected of a Plain finish subject to the comments below

Surface Blemishes

Larger holes require filling to meet 10mm requirement and fewer should be expected

Note examples of bolt hole filling - flush and recessed

Note: Mastic sealing of joints in formwork would reduce grout loss at edges

Abrupt Irregularities

All within 2mm requirement

Colour

Black stains caused by handling during erection of panels
Color variation is as expected on reuse may reduce with weathering

General

Both sides meet the specification with filling of large hole blemishes

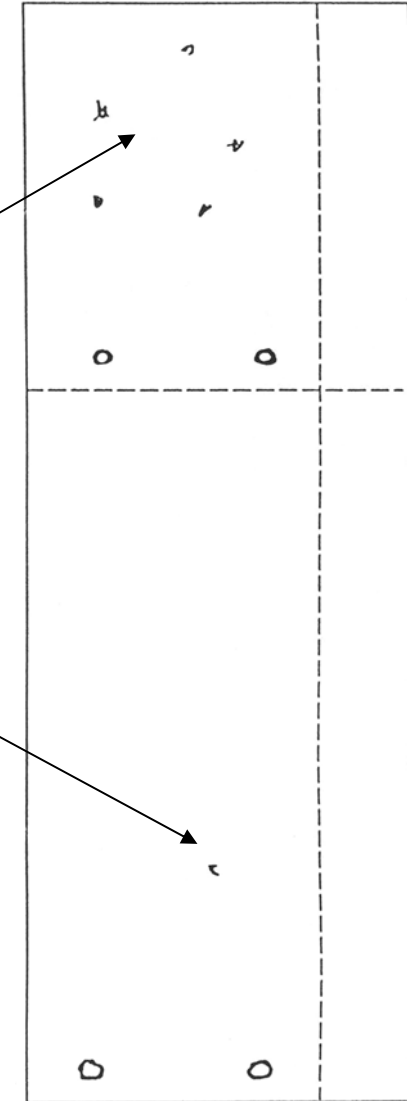

LOCATION OF ALL SITES IN UK DISPLAYING PANELS

| | | | |
|---------------------------------------|---|---|------------------|
| London North (External Site) | John Doyle Construction Limited John Doyle House Little Burrow, Welwyn Garden City Herts AL7 2SP | Tel: 01707 329481 E-mail: graham.hardwick@john-doyle.co.uk | Graham Hardwick |
| London South (External Site) | The Medway School of Engineering Medway University Campus University of Greenwich Chatham Maritime, Kent ME4 4TB | Tel: 0208 331 8368 E-mail: t.d.stevens@gre.ac.uk | Tony Stevens |
| South West England (External Site) | University of the West of England Faculty of Environment and Technology School of Built and Natural Environment Coldharbour Lane Frenchay Bristol BS16 1QY | Tel: 0117 328 3191 E-mail: ghassan.nounu@uwe.ac.uk | Dr Ghassan Nounu |
| Central England (External Site) | Peri Ltd Market Harborough Road Clifton upon Dunsmore Rugby CV23 0AN | Tel: 01788 861600 E-mail: matthew.binder@peri.ltd.uk | Matthew Binder |
| North East England (Internal Site) | University of Sheffield Sir Frederick Mappin Building Mappin Street Sheffield S1 3JD | Tel: 0114 222 6690 E-mail: p.blackbourn@sheffield.ac.uk | Paul Blackbourn |
| Scotland (Internal Site) | University of Paisley High Street Paisley PA1 2BE | Tel: 0141 848 3280 E-mail: bill.matthews@uws.ac.uk | Bill Matthews |



LOCATION OF PANELS

Scotland

University of Paisley
Paisley Campus
Glasgow

North East England

University of Sheffield
Mapping Street
Sheffield

Central England

Peri Ltd
Clifton upon Dunsmore
Nr Rugby

London North

John Doyle Construction Ltd
Welwyn Garden City
Herts

London South

Medway University Campus
University of Greenwich
Chatham Maritime

South West England

University of the West of England
Coldharbour Lane
Bristol